

# AQUAMATIC



# ANVIL

## HOT TAP



- Introducing Aquamatic's first 3 in 1 instant hot water kitchen tap
- This versatile solution provides hot, cold and 98°C filtered boiling water.
- Dedicated purifying water filter provides optimum taste and odour enhancement through premium chlorine reduction and phosphate crystals for scale reduction and tank protection.
- Childproof boiling water handle includes a safety button and springback function, ensuring the boiling water flow stops immediately when released.
- Adjustable temperature setting up to 98°C
- 2.4 litre tank capacity holds enough water for over 10 (225ml) cups of tea or coffee at any time
- Unique heat insulation technology keeps the spout cool to the touch
- Bespoke Neoperl aerator, manufactured specifically for a soft, splash-free flow of water.
- Fully WRAS approved and NHBC building regulations compliant.
- Compact tank, fits neatly into most undersink cupboards.



# SPECIFICATIONS

- Minimum Operating Pressure: 1 BAR
- Maximum Operating Pressure: 4 BAR
- Number of Handles: ONE
- Handle Style: ROD
- For Use With: ANVIL FILTER ANVIL TANK
- Material: Brass
- Colour: CHROME
- Finish: POLISHED
- WRAS: YES
- Years Guaranteed: TAP 5 YEARS, TANK 2 YEARS  
(Provided filters are changed every 6 months)
- Power Required: 13 AMP PLUG
- Tank Dimensions: 190w x 190d x 295h

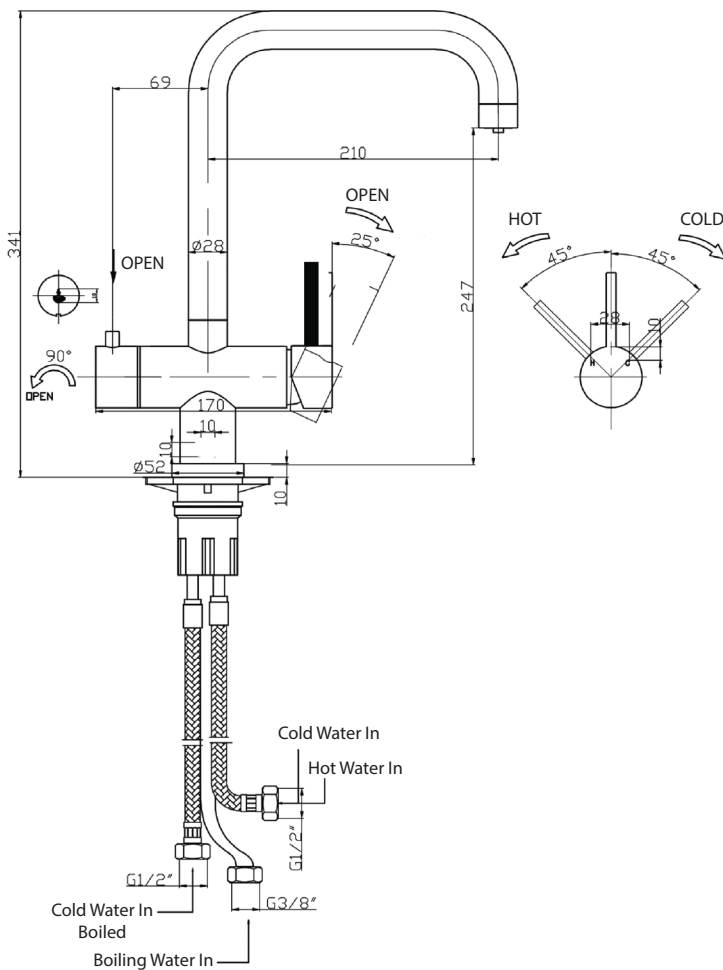

Tel: +44 1483 861599

Email: [sales@aquamatic.co.uk](mailto:sales@aquamatic.co.uk)